



**S-40XL Spreader  
ART.059.952.2**

**GENESIS™**  
S E R I E S

# USERS GUIDE



**AMERICAN**  
RESCUE TECHNOLOGY INCORPORATED

240 Warren Street  
Dayton, Ohio 45402  
Tel. (937) 228-2200  
Fax. (937) 228-3300  
<http://www.art4rescue.com>  
e-mail: [amres@erinet.com](mailto:amres@erinet.com)

Thank you for choosing equipment from **American Rescue Technology**. We strive to give our customers the latest technology available in rescue products; from the newest lightweight alloys, to the most innovative designs in the industry. We continually update and refine our products in order to offer the highest quality equipment at a reasonable price. All of our **Genesis Series** spreaders are forged from aircraft grade aluminum alloy and protected with a hard anodize finish. The spreading tips are forged from shock resistant tool steel. **The S-40XL** spreader is third party tested, **ISO 9001 Quality Assurance Certified and NFPA 1936 Compliant**. At **American Rescue Technology** we feel we offer the highest quality rescue equipment available; so do our customers! Thank you again for choosing **American Rescue Technology**.

## Read Before Operating

Read and follow this manual and safety regulations prior to operation.

- Only trained and qualified personnel are authorized to use this spreader.
- Operator must wear protective clothing, helmet, eye protection, and gloves.
- No modifications in shape or performance is allowed. Changing the pressure relief valve of the hydraulic power unit is not allowed.
- This spreader is designed for the use described in this manual. Other applications are not permitted.
- Before operating spreader, all by-standers must be removed from area.
- This spreader should never be connected or disconnected to hydraulic hoses if pressure is present in the hoses.

## Applications

The spreader is designed for spreading body parts on vehicles. They are used to rescue trapped or endangered patients: To displace doors, roofs, door posts, and other obstacles encountered during rescue operations.

The spreaders are also used for industrial purposes, e.g. to spread open molds, destruct testing, general lifting and pulling.

### Connecting the Spreader

Remove the protective caps from the male (1) and female (2) coupler.

#### Connecting

Grasp the male coupling in one hand and with the other grasp the female coupler and draw back the sleeve, be sure the pin and slot are aligned. Bring the ends together and press. Release and turn the sleeve to ensure couplers are connected.

#### Disconnecting

Grasp the coupler pair and draw back on the sleeve of the female coupler. Make sure the pin and slot are aligned and the coupler will disconnect. A few drops of fluid may be expelled. This is normal.

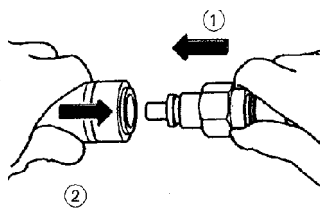

## Operating Spreader

The operation of the spreader is controlled by a push-button “dead man” control.

**Neutral Position:** The push-button is held in the center position when not in use.

**Opening:** Press wedge-end knob (bottom button)-  
←|→ spreader arms open.

**Closing:** Press spherical knob (top button)-  
→|← arms close.

**To Stop Movement:** Release push-button. The spreader arms stop moving immediately (neutral position). The operating pressure built up in the spreader, by the load, remains. The oil flow passes through the control handle allowing the tool to stop moving and hold the load in any position.

To re-start press push-button side marked “open” or “close” as required. The operating speed of the spreader is controlled by the pressure exerted on the push-buttons. Maximum speed and pressure can only be reached by completely depressing the push-button.

### Operation of Over-Pressurization Relief Valve

If the couplers have not been properly engaged, preventing the return flow of fluid back to the power unit, a relief valve in the control handle automatically releases fluid. This causes a fluid leak, from the hole, between the hoses on the control handle. Immediately switch the power unit to the neutral position and connect the couplings correctly.

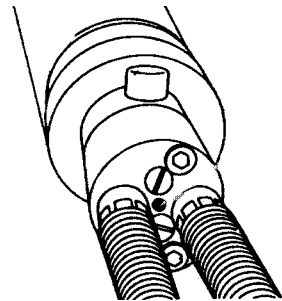

### Disconnecting of the Spreader

When disconnecting the spreader from the power unit hoses, the power unit must be in the neutral position. The spreader can now be disconnected and another tool connected.

## General Maintenance

Following are the recommended service intervals for your new rescue equipment. By following these guidelines you will be assured many years of reliable service.

### After Each Use

- Wipe down all equipment to remove debris
- Clean male and female couplers
- Clean spreader arms and tips
- Check whipends for damage
- Check spreader tips for damage

### Weekly Inspection & Maintenance

We recommend running the tools weekly and doing the following checks.

- Check all couplers and fittings for tightness
- Run each tool and build full pressure
- Check handles and guards, tighten if necessary

### Yearly Maintenance

We recommend having a yearly inspection and service done by a qualified American Rescue Technology technician.

- Cleaning, greasing and inspection of spreader
- Dressing spreader tips, if necessary
- Pressure test spreader, adjust if necessary

### Cleaning the Couplers

Below is a photo of a dirty female coupler. Dirty couplers allow dirt to get into the hydraulic system, requiring more frequent fluid changes. Dirty couplers are difficult to connect and lead to further complications. To clean a coupler, we recommend immersing it in hydraulic fluid and agitating it until the dirt is removed. Petroleum based penetrating oil will also work. (WD-40) These are available in sprays and are well suited for field use.

**Clean dirty couplers with hydraulic fluid or a light penetrating oil like WD-40.**



## Lubricating Spreader

Follow the directions below to disassemble and reassemble the spreader. The number beside each part coincides with the part on the parts diagram. Disassemble and lubricate the spreader using molybdenum disulphide grease. All pivot points and moving surfaces should be lubricated. Open spreader arms about 4" before starting. **Caution: Disconnect spreader from power unit before proceeding. Spreader should not be under load when disassembling.**

1. Loosen Phillips head screws (22) and remove side handle. (24)
2. Remove hex head (21) and Allen head plugs. (27)
3. Remove bottom guard plate. (6)
4. Remove 4 snap rings (20) from bottom of spreader.
5. Remove top handle (5) with pivot pins (25) and top guard plate (6) attached.
6. Remove pivot pins (16) from arms.
7. Remove center pivot pin. (7)
8. Remove arms. (4)
9. Lubricate all pivot points and moving surfaces.
10. Reassemble in reverse order.

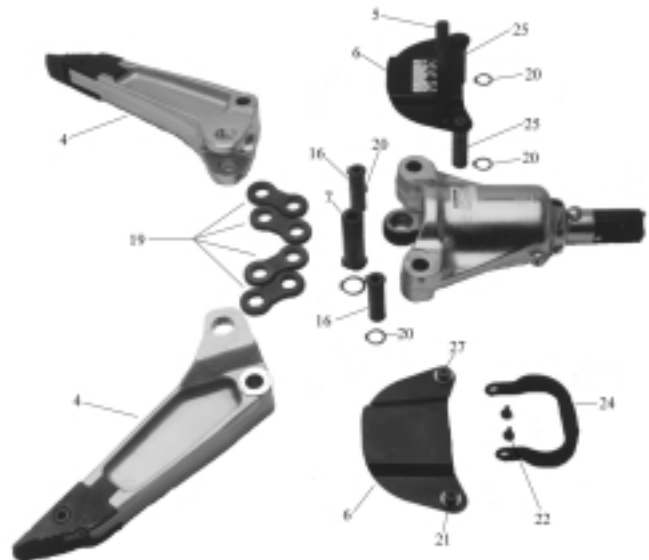

## Specifications

	<b>S-40XL</b>
<b>Length (in/cm)</b>	32/813
<b>Width (in/cm)</b>	9.75/248
<b>Height (in/cm)</b>	8/203
<b>Weight (lbs/kg)</b>	43/19.5
<b>Travel Distance (in/cm)</b>	27.6/700
<b>Operating Pressure (max. psi/bar)</b>	10,000/700
<b>HSF- Highest Spreading Force (lbs./kN)</b>	13,900/61.8
<b>LSP- Lowest Spreading Force (lbs./kN)</b>	10,500/47.0
<b>HPF- Highest Pulling Force (lbs./kN)</b>	11,100/49.6
<b>LPF- Lowest Pulling Force (lbs./kN)</b>	9,100/40.6
<b>Maximum Spreading Force (lbs./kN)</b>	29,000/132
<b>Opening Time (sec)</b>	7.7
<b>Closing Time (sec)</b>	6.2
<b>Part Number</b>	ART.059.952.2

## Genesis Series Spreaders

Your new Genesis spreader will provide you with many years of reliable service. All of the Genesis Series tools require little maintenance. We suggest following the guidelines as stated under the General Maintenance section of this guide. On a yearly basis disassemble, clean and grease all of the moving parts and linkage on the spreader arms. The spreader should also be pressure tested and adjusted if necessary. Any adjustments to the pressure settings should be done by a qualified American Rescue Technology technician.

### Tip Placement When Spreading

The most important thing when using a hydraulic spreader is tip placement. The placement of the tips will determine how successful your spreading operation will be. Here are a few suggestions.

- Always look for a solid surface to spread against. Single layers of sheet metal usually tear. Look for folds, double thickness or formed areas to spread against.
- When spreading a nader pin, make the final spread with the tips near the flat head screws that mount the locking mechanism.
- NEVER spread with the tips on the heads of bolts. This will concentrate the force on a small area of the tips and could cause damage. (See photo below)
- Always insert the spreader tips as deep as possible. This will spread the force over a larger area and give a better grip.
- Always spread with the tips not the arms.



## Set-Up Procedure

**If any hydraulic leaks are detected at any time immediately shut system off.**

1. Remove spreader from box.
2. Remove packing material from spreader and clean.
3. Check tightness of hose connections and couplers.
4. Check tightness of handle bolts.
5. Connect spreader to power unit.
6. Start power unit and engage pump valve.
7. Allow fluid to circulate for 2 minutes.
8. Open and close spreader a few times. This will remove any air in the system.
9. Build pressure by fully opening and closing the spreader a few times.
10. Spreader is ready for use.

### Cleaning Spreader Tips

When necessary, clean the spreader tips with a wire brush. Removing the dirt and metal particles from the surface of the tips allows the spreader to grip better during spreading operations.

Small “nicks” and burrs can be removed with a file. Never file more than 2 mm of material from the tips. When filing a tip ensure that the original angle and profile are maintained. Large gouges and broken tips need to be replaced. Contact your local dealer or American Rescue Technology, Inc.

### Using Chain Packages

There are two types of chain packages available for the S40-XL spreader. the Quick Adjust Chain Package and the Standard Chain Package.

When using the quick adjust chain package (P/N: ART.281.913.9) remove spreader tips and add the shackle assembly to arms. Use the pins provided with the chain package and insert them through the spreader arms.

When using the Standard chain Package (P/N: ART.281.915.9) remove pins from spreader tips, put chain shackle over tips. Insert pins, provided with chain package, through the chain shackle, tips and arms before using.

---

---

## Troubleshooting

Problem	Reason	Action
Tool not achieving maximum performance.	Push-button not completely depressed.	Depress push-button completely
Arms won't move or tool runs backward.	Coupler set on backwards	Find reversed coupler set and repair
Spreader cannot be connected to hose.	Pressure build-up in hose.	Put pump valve to dump or neutral position
Fluid leaks at back of control handle.	Return line not properly connected	Check coupler connections
Spreader opens and closes slowly	Clogged filter or flow restrictor	Check tool filters and flow restrictors
Hoses have cuts and abrasions and wire braids are exposed.	Hoses showing signs of wear	Replace hoses
Fittings or couplers leaking	Loose fitting or coupler or bad seal	Replace seal if bad. Tighten

**Parts and service are available through your local dealer or contact American Rescue Technology, Inc. Before disassembling tools contact your local dealer or American Rescue Technology, Inc.**